

DBS315/322/300

DESCRIPTION

Dutair blowers for pressure and vacuum are compact machines consisting of an electric motor with a built-on pump housing. The rotational speed of the impeller creates a high compression of the internal air, resulting in a vacuum at the inlet and pressure at the outlet of the blower.

This process works without any contact, thus eliminating wear and the need for lubrication.

FEATURES

- compressor and vacuum pump in a single unit
- robust
- oil-free
- low noise levels
- low vibration levels
- maintenance free
- vertical mounting with in- / outlet pointing upwards possible
- integrated silencers
- many different applications

BENEFITS

- high motor efficiency and excellent power factor yield lower electrical consumption
- accurate performance curves in a frequency range of 30 to 80 Hz make Dutair blowers suitable for applications with a wide operating area
- detailed sound level data for acoustic purposes
- Dutair blower motors are fitted with PTC thermistors as standard
- a variety of modifications possible for non-standard applications



DBS322

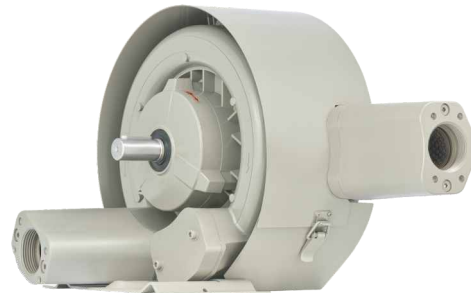

DBS300

GENERAL TECHNICAL DATA

		DBS315		DBS322		DBS300
		50 Hz	60 Hz	50 Hz	60 Hz	bare shaft
Power ^①	kW	1.75	1.9	2.2	2.6	max. 2.6
Voltage Δ / Y ^②	V	230/400	265/460	230/400	265/460	-
Current Δ / Y	A	6.4/3.7	5.9/3.4	7.8/4.5	7.5/4.3	-
Revolutions	/min	2880	3490	2900	3460	1750...4500
Protection class ^③		IP55	IP55	IP55	IP55	-
PTC Thermistors ^④	°C	140	140	150	150	-
Efficiency class ^⑤		IE2	IE1	IE3	IE2	-
Efficiency ^⑥	%	82.1	83.4	86.5	86.0	-
Power factor	%	87.1	84.5	86.0	92.1	-
Sound pressure ^⑦	dB(A)	64.4	66.6	65.5	69.5	-
Weight	kg	25	25	28	28	19

^①see notes on page 7

DBS315/322/300

PERFORMANCE

Static pressure difference between in- and outlet Δp_s against airflow Q at an ambient condition of 1013 mbar and 20 °C. All duty points on characteristics curves are in thermal equilibrium[®]. Flow is rated in Nm³/h defined as air, 1013 mbar and 0 °C. Tolerance +/-3%. See notes on page 7.

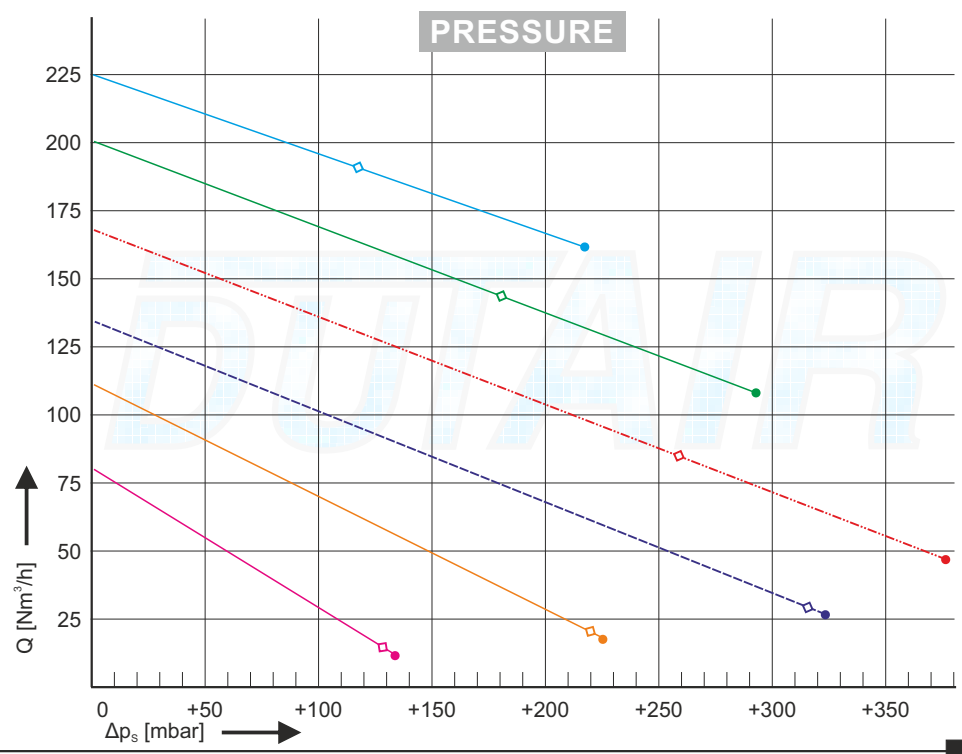
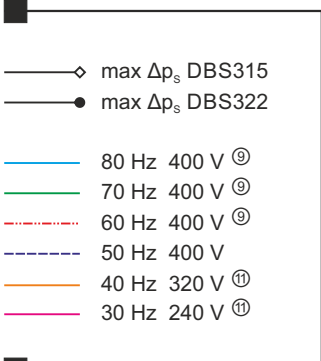

TEMPERATURE RISE

Temperature rise ΔT measured directly at in- and outlet. Ambient condition of 1013 mbar and 20 °C. All duty points on characteristics curves are in thermal equilibrium[®]. Tolerance +/-5 °C.

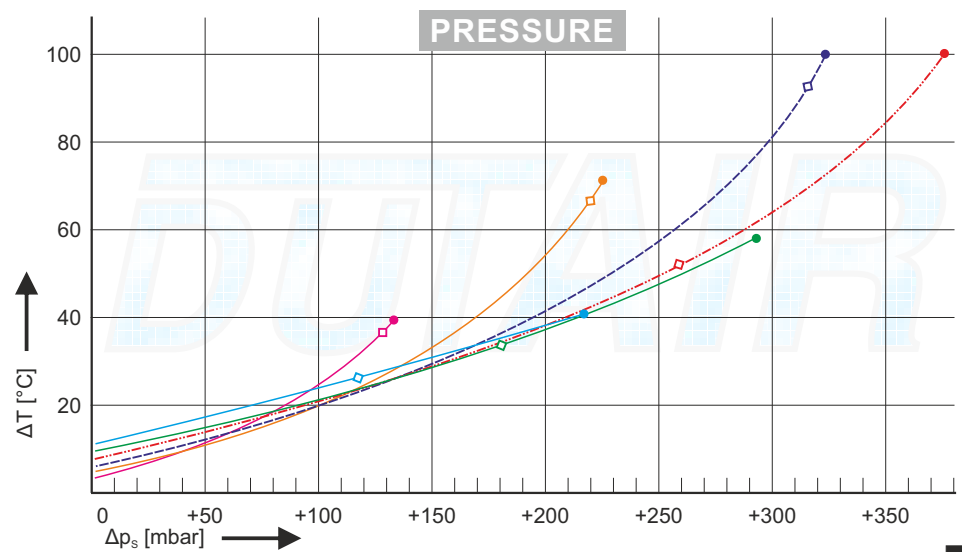

POWER

Motor power P delivered at impeller shaft. Ambient condition of 1013 mbar and 20 °C. All duty points on characteristics curves are in thermal equilibrium[®]. Tolerance +/-5%. Accurate data on current consumption for specific duty points available on request.

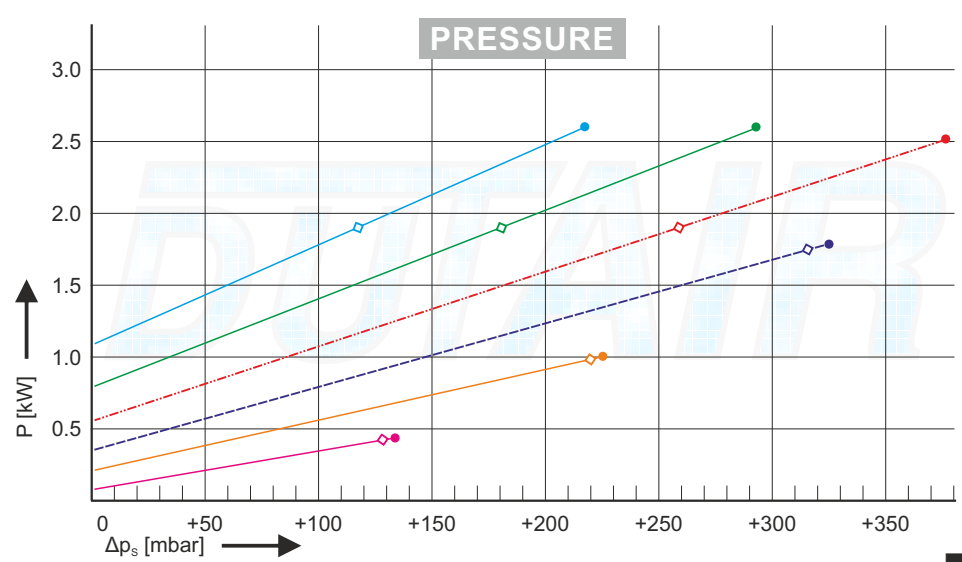

DBS315/322/300

PERFORMANCE

Static pressure difference between in- and outlet Δp_s against airflow Q at an ambient condition of 1013 mbar and 20 °C. All duty points on characteristics curves are in thermal equilibrium[®]. Flow is rated in Nm³/h defined as air, 1013 mbar and 0 °C. Tolerance +/-3%. See notes on page 7.

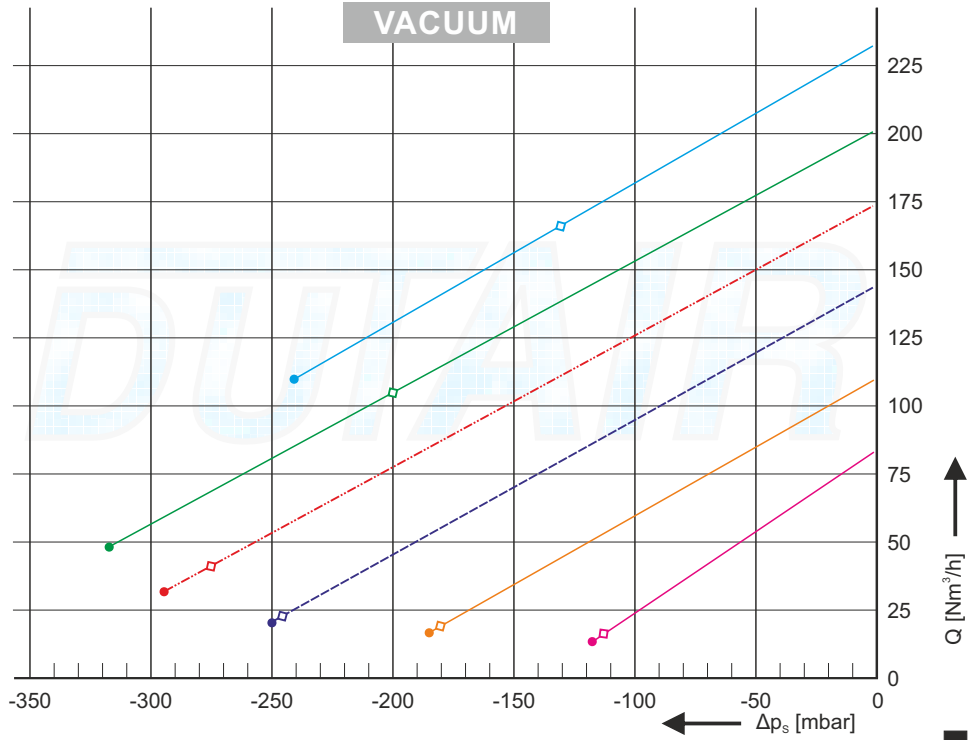
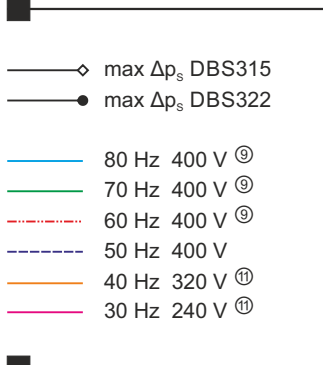

TEMPERATURE RISE

Temperature rise ΔT measured directly at in- and outlet. Ambient condition of 1013 mbar and 20 °C. All duty points on characteristics curves are in thermal equilibrium[®]. Tolerance +/-5 °C.

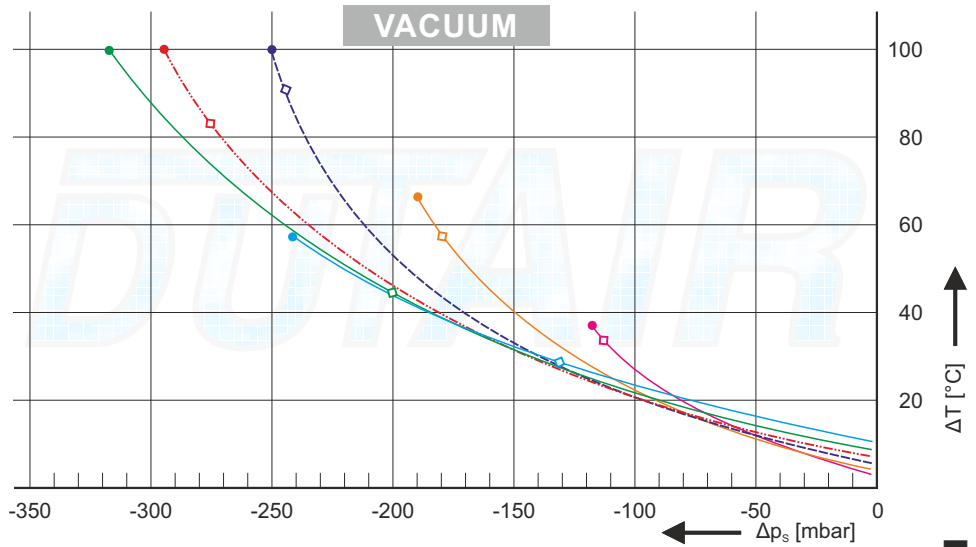

POWER

Motor power P delivered at impeller shaft. Ambient condition of 1013 mbar and 20 °C. All duty points on characteristics curves are in thermal equilibrium[®]. Tolerance +/-5%. Accurate data on current consumption for specific duty points available on request.

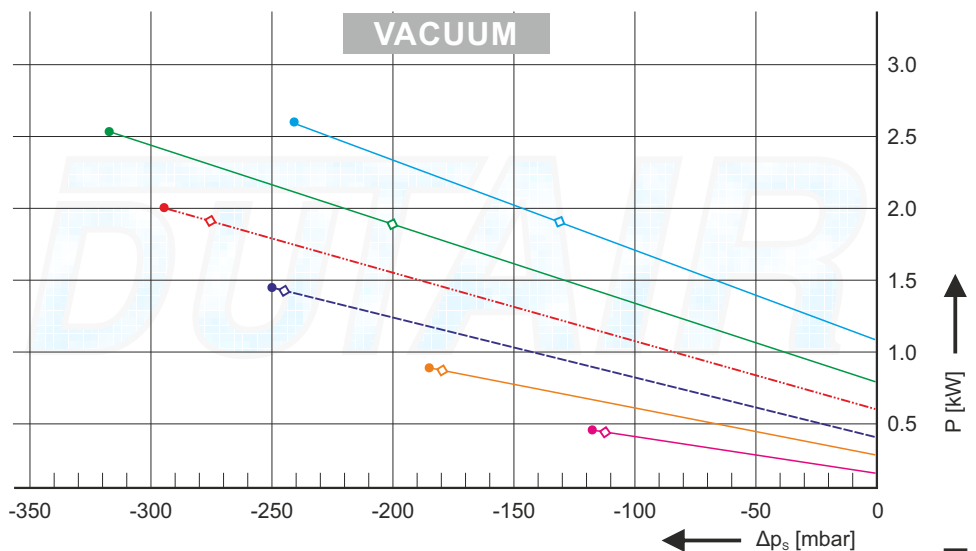

DBS315/322/300

SOUND LEVEL PRESSURE DBS315

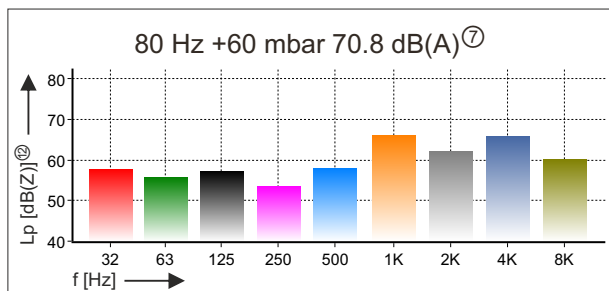
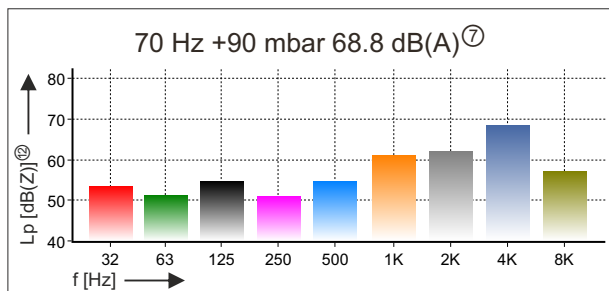
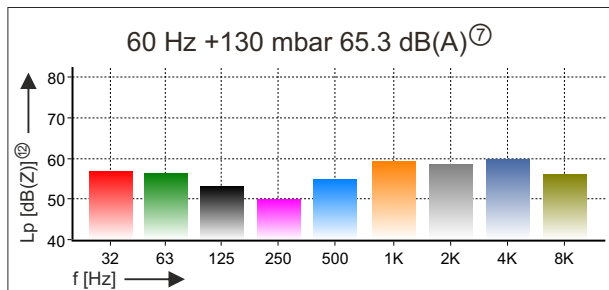
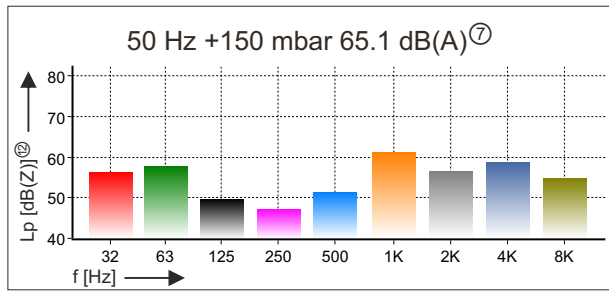
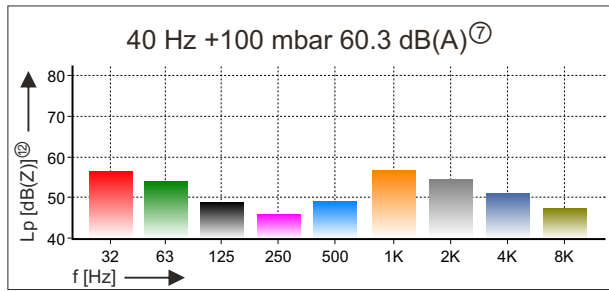
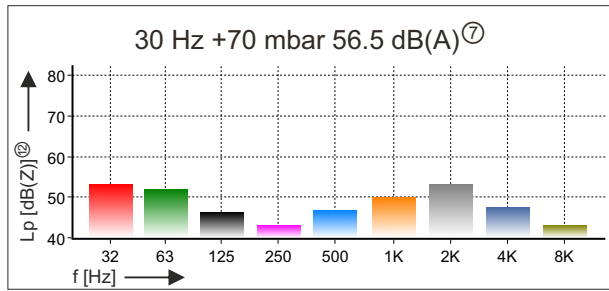

SOUND LEVEL VACUUM DBS315

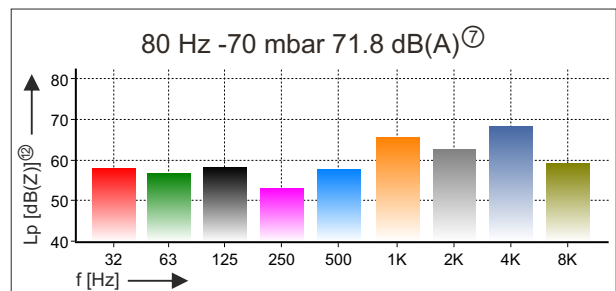
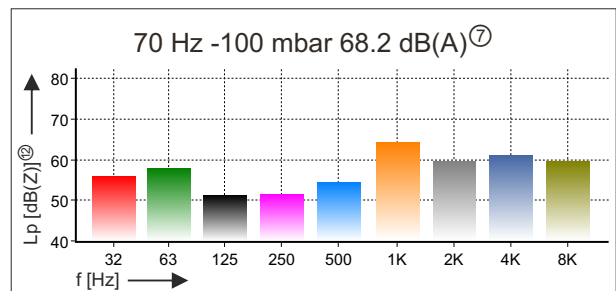
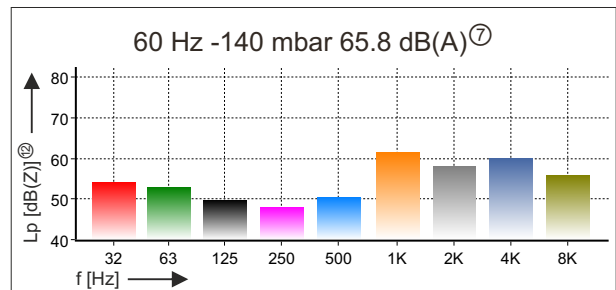
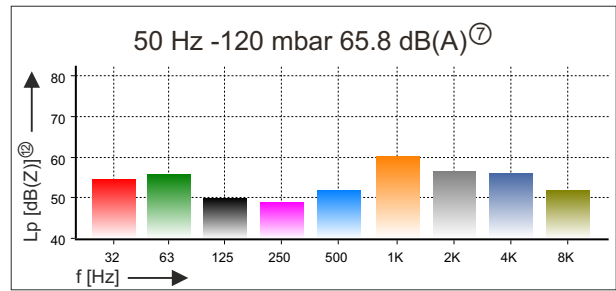
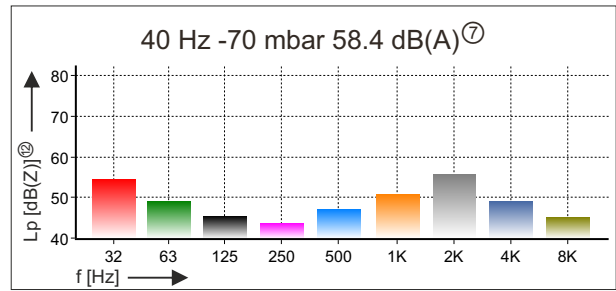
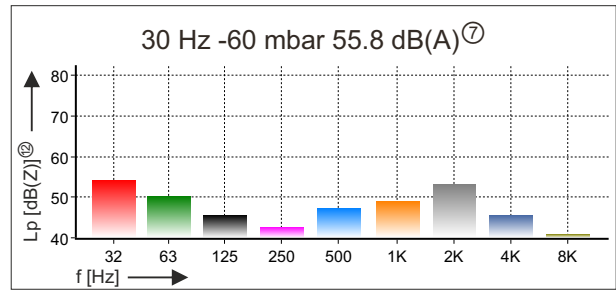

DBS315/322/300

SOUND LEVEL PRESSURE DBS322

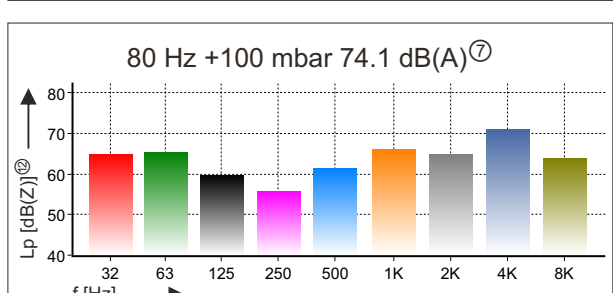
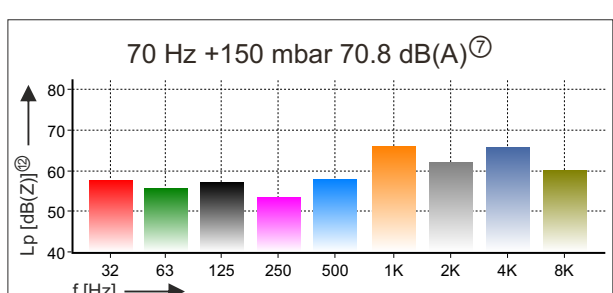
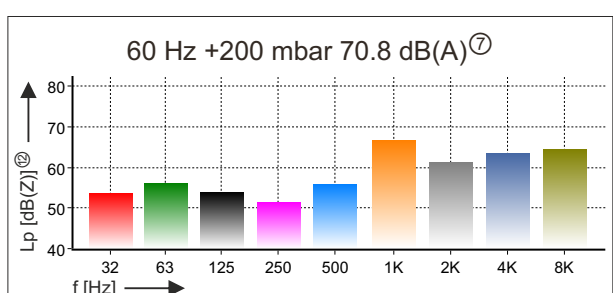
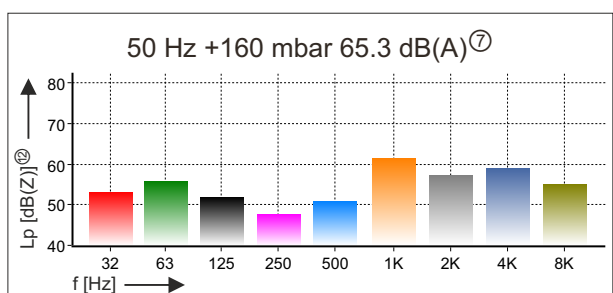
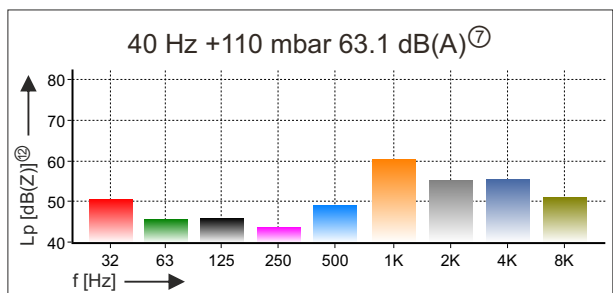
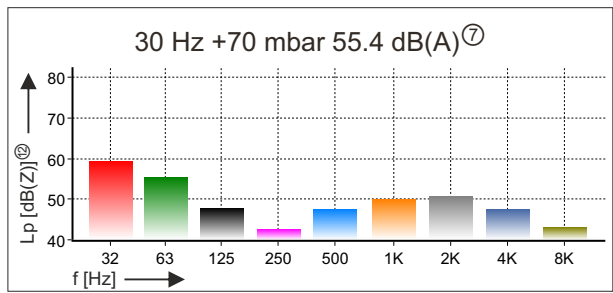

SOUND LEVEL VACUUM DBS322

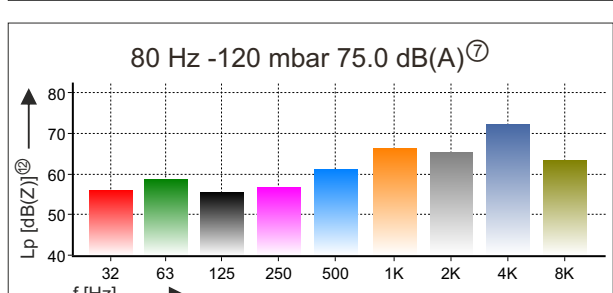
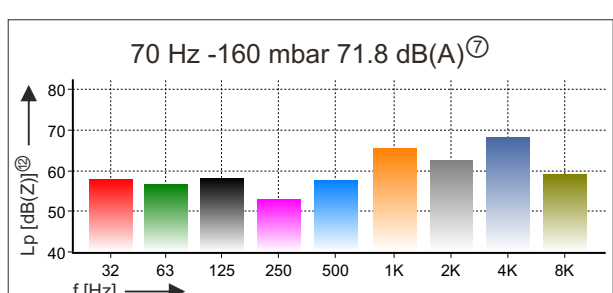
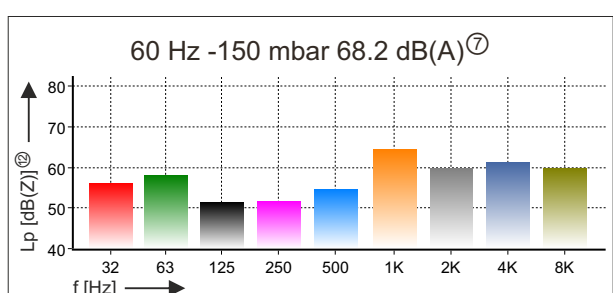
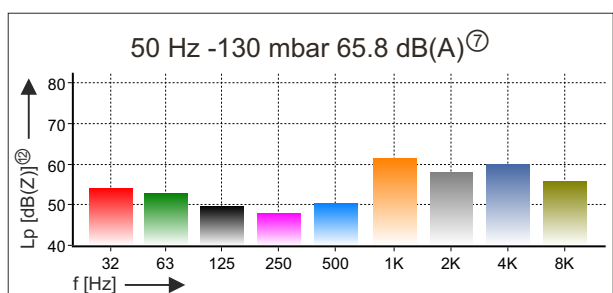
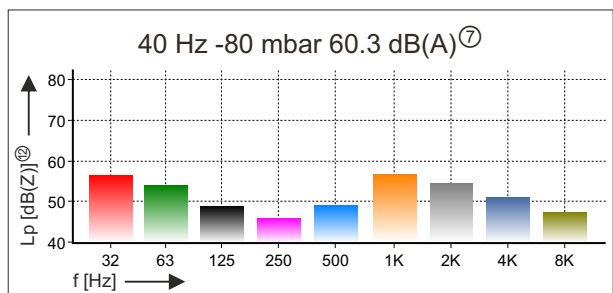
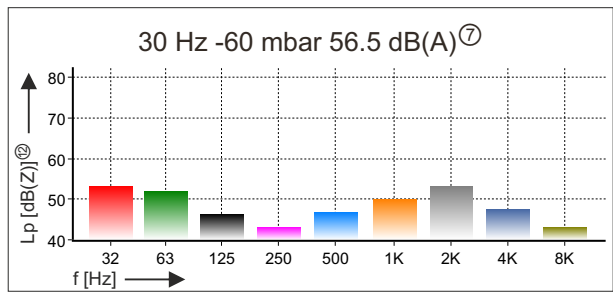

DBS315/322/300

DIMENSIONS DBS315/322

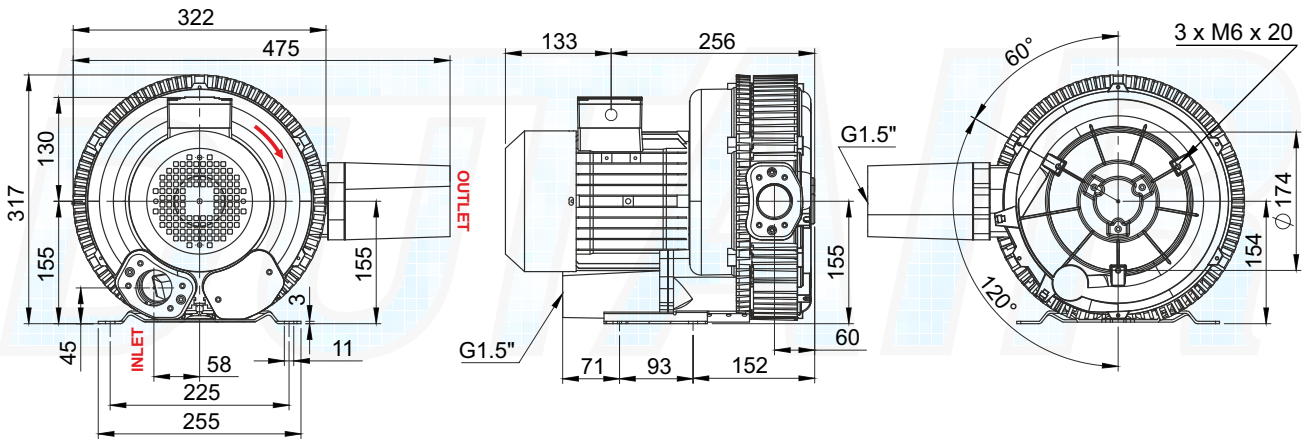

DIMENSIONS DBS300

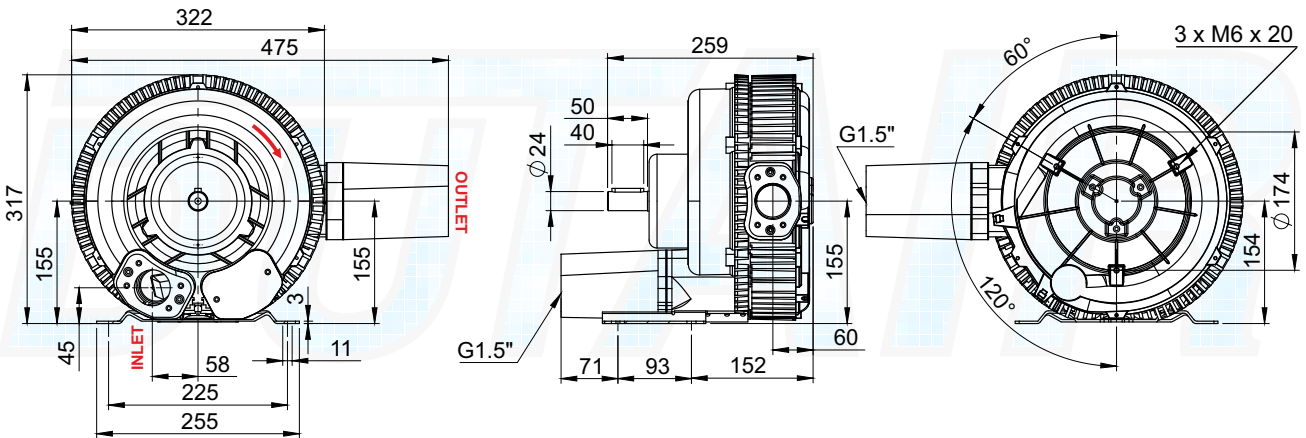

- all dimensions in mm except in- and outlet connection
- CAD models available in STEP format
- tolerance +/- 2 mm
- in case of discrepancy between dimensional drawing and CAD model, dimensions in dimensional drawing take precedence

DBS315/322/300

ORDERING INFORMATION

53	DB	S	5	75	U...-..	ss	HT	RS	FE	IP56	Q	G	Ex	C...
51 : single phase / 53: three phase	Dutair Blower	S: Double stage serial blower P: Double stage parallel blower	Blower size	Motor size	Optional special motor voltage e.g. U500-50: 500 V at 50 Hz version	Optional bearing material ss: stainless steel	Optional bearing lubrication ^⑭ HT: high temp. / LT: low temp.	Optional bearing material RS: Improved resistance against moisture	Optional seal on motor shaft FE: PTFE seal / Vi: Viton seal	Optional motor protection: IP56 / IP65, for IP56 specific mounting position	Optional Q: anti condensation heating 230 V	Optional G: blower in gas-tight version available for single stage blowers	Optional ATEX non-sparking version ATEX Ex II Cat 3G/3D Ex-na	Optional painting: standard RAL7023 e.g. C7035: RAL7035

COMMENTS

WARNING: Comparing performance data can be misleading. Dutair specifications are based on a thermal equilibrium[®] for all duty points along the characteristics curves in this document. Many commercial based flow characteristics curves defined as m³/h air at 20 °C, 1013 mbar(a) and +/-10 % tolerance but can be up to 40 % higher than accurate characteristics curves defined as Nm³/h air at 0 °C, 1013 mbar(a), thermal equilibrium[®] duty points and +/-3 % tolerance as specified in this Dutair document.

The performance measurements are executed with instruments calibrated by DNV KEMA and are traceable to primary and/or internationally accepted measurement standards.

- ① Maximum shaft power allowed at continuous operation.
Rated output electric motor in accordance with NEN-EN-IEC 60034-1.
- ② Rated voltage for three phase triangle and star connection. Allowed supply voltage tolerance 5 %.
Consult your Dutair dealer for different supply voltages.
- ③ Protection class in accordance with NEN-EN-IEC 60034-5.
- ④ 3 pieces PTC thermistors connected in series fitted in each motor phase.
- ⑤ Efficiency classification in accordance with NEN-EN-IEC 60034-30.
- ⑥ Efficiency rated at 100% motor load.
- ⑦ Free field equivalent continuous sound pressure level A-weighted L_{eq}[dB(A)].
Unless specified L_{eq}[dB(A)] rated at 50 % of maximum pressure at 50 Hz. Tolerance +/- 2 dB(A).
Conditions as note ⑬.
- ⑧ Thermal equilibrium is the state reached when the temperature rises of several parts of the machine as well as the temperature rise between in- and outlet do not vary by more than a gradient of 2°C per hour.
- ⑨ Operation at 400 V within range of 60 to 80 Hz: 110 % of rated current at 50 Hz is allowed for 60 Hz power rating.
- ⑩ N/a.
- ⑪ Maximum performance at 30 & 40 Hz is limited by temperature rise as well as current. At 30 Hz 60 % and at 40 Hz 80 % of nominal motor current.
- ⑫ Free field class 1 octave band measurements in accordance with IEC 61260 unweighted L_p[dB(Z)].
Tolerance +/- 5 dB(Z). Conditions as note ⑬.
- ⑬ Measurements at 1 m distance with in- and outlet duct connected to the blower on a reflective surface.
Class 1 sound level meter Delta Ohm HD2010UC/A according to IEC 61672-1.
Acoustic calibration prior to measurements with class 1 calibrator HD2020ACC according to IEC 60942.
- ⑭ Standard ambient temperature range -20...+40°C.